



 **EMBRAER**

c-390.com

C-390
MILLENNIUM

UNBEATABLE COMBINATION

 **EMBRAER**

C-390 MILLENNIUM



UNBEATABLE COMBINATION

The new generation military multi-mission transport aircraft C-390 Millennium is the answer to the 21st-century demands, with unrivaled mobility and operational flexibility in a single platform.

C-390 Millennium provides optimal fleet performance, generated by a cost-effective combination of high availability and productivity.

- > RAPID RECONFIGURATION AND THE LATEST TECHNOLOGY
- > OPERATIONAL EFFICIENCY AND LOW LIFE-CYCLE COSTS
- > SPEED IN THE AIR AND FASTER TURNAROUNDS

MISSION MODULES

ONE AIRCRAFT, MANY CAPABILITIES

- AERIAL ASSAULT**
- AERIAL FIREFIGHTING**
- AERIAL RESUPPLY**
- SEARCH AND RESCUE**
- SPECIAL OPERATIONS**
- HUMANITARIAN AID**
- MEDICAL EVACUATION**
- AIR-TO-AIR REFUELING**

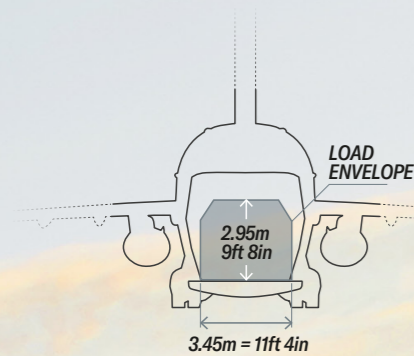
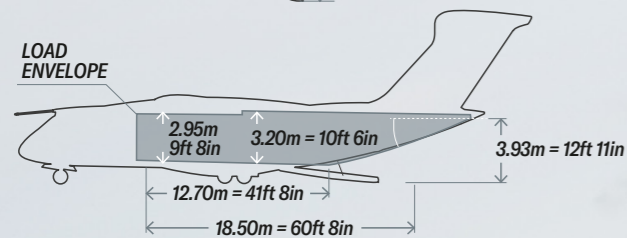
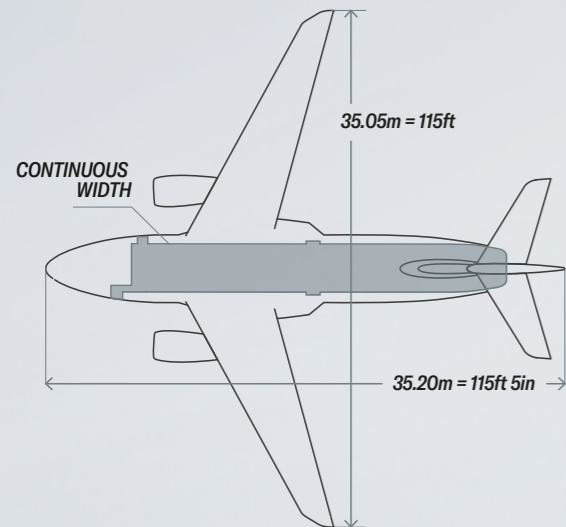

NO SCHEDULED AIRFRAME DEPOT LEVEL MAINTENANCE

Routine check:
Every 14 days of operation → ~4 man-hours

Intermediate checks:
600 FH or 12 months → ~12 days

Basic checks:
60 months → ~25 to 40 days

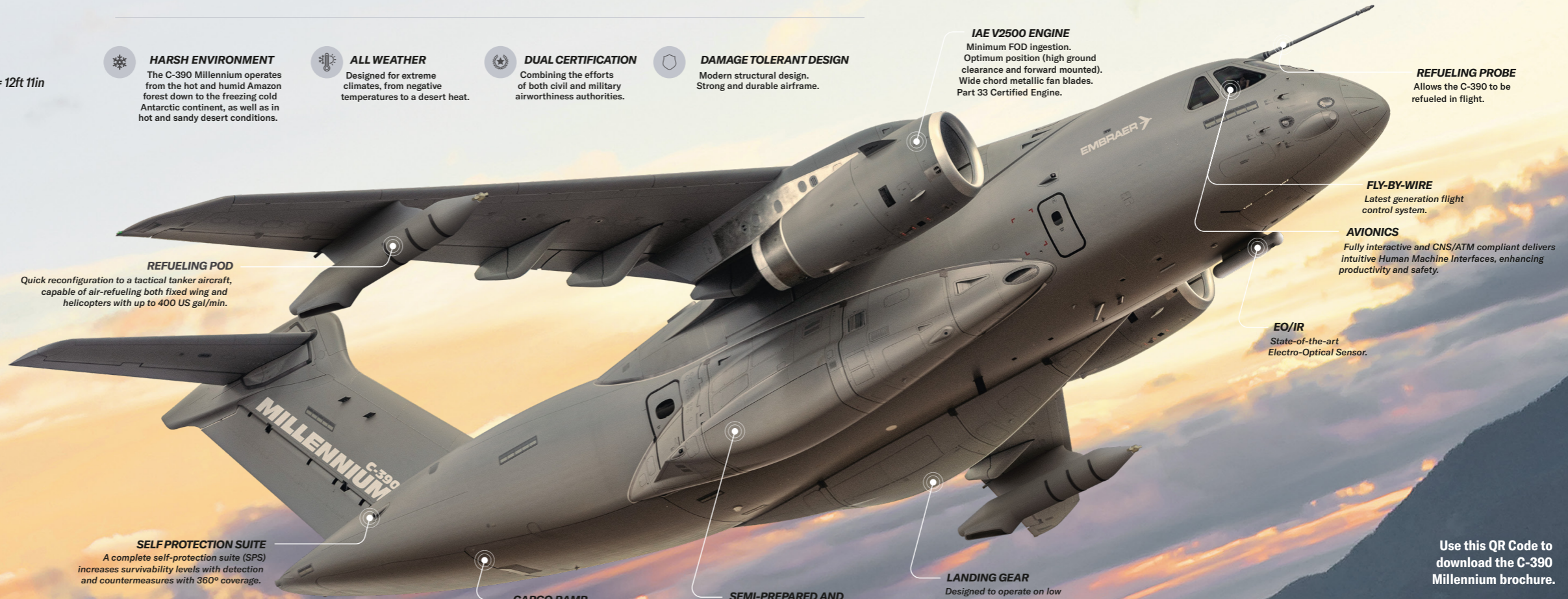

REFUELING POD
Quick reconfiguration to a tactical tanker aircraft, capable of air-refueling both fixed wing and helicopters with up to 400 US gal/min.

SELF PROTECTION SUITE
A complete self-protection suite (SPS) increases survivability levels with detection and countermeasures with 360° coverage.

CARGO RAMP
Loading and unloading ramp equipped with the market's most advanced cargo handling and aerial delivery system.

SEMI-PREPARED AND DAMAGED AIRFIELD OPERATION
Worst Semi-Prepared and Damaged Runway from MIL-B-8866B.

LANDING GEAR
Designed to operate on low resistance airfields (CBR-4), brake-by-wire, wheel-by-wheel.

EO/IR
State-of-the-art Electro-Optical Sensor.

AVIONICS
Fully interactive and CNS/ATM compliant delivers intuitive Human Machine Interfaces, enhancing productivity and safety.

FLY-BY-WIRE
Latest generation flight control system.

REFUELING PROBE
Allows the C-390 to be refueled in flight.

IAE V2500 ENGINE
Minimum FOD ingestion. Optimum position (high ground clearance and forward mounted). Wide chord metallic fan blades. Part 33 Certified Engine.

PARATROOPERS
Capacity for 64 fully equipped paratroopers or 80 troops

SEMI-PREPARED RUNWAYS

LIGHT AND HEAVY VEHICLES
Capacity for 3 to 4 light vehicles or 1 to 2 heavy vehicles

PALLETS
Capacity for 7x 463L pallets or 24x CDS 48"x48" packages

HELICOPTERS
Capacity for one Black Hawk or similar size helicopter

MEDEVAC STRETCHERS
Capacity for 74 litters with 8 attendants or 50 litters and 36 pax

THE MOST COMPREHENSIVE FLEXIBILITY

C-390 is capable of transporting a maximum of 50,706 lb (23,000 kg) of distributed loads and a maximum concentrated load of 57,320 lb (26,000 kg)

Use this QR Code to download the C-390 Millennium brochure.



c-390.com